



Hidrolik Pres Sistemleri

Hydraulic Presses Systems



FARUK USTA HİDROLİK PRES MAK. SAN. ve TİC. LTD. ŞTİ.

KONHİDRO



FARUK USTA HİDROLİK PRES MAK. SAN. ve TİC. LTD. ŞTİ.



Kurumsal Company

1982'den bugüne yılların vermiş olduğu tecrübe ve deneyimler ile birlikte hidrolik pres sektöründe markalaşma yolunda giden KONHİDROLİKSAN FARUK USTA HİDROLİK PRES, kaliteli üretimi gaye edinip, yatırımlarını bu gayenin gerçekleşmesi için planlamaktadır. Edindiğimiz tecrübeler müşterilerimize optimum fayda sağlama ve güvenilirlik unsurlarının sağlanmasında verdiğimiz garantidir. Entegre çözümler üretip, farka fark katan firmamız yeniliklerin takipçisi değil öncüsü olmayı istemektedir. Uzman kadrosu ile kurumsal yönetim amacını gözeten KONHİDROLİKSAN ülkesinde yakaladığı başarıyı yurtdışında da yakalamak için profesyonel üretimler gerçekleştirmektedir.

KONHİDROLİKSAN olarak temel hedefimiz, müşterilerimizin ihtiyaçlarını ve beklentilerini karşılayacak üstün kalitede hidrolik presler üretmek ve satış sonrası servisi ile hizmetler sunarak, sağlıklı ve sürdürülebilir büyümeyi sağlamaktır.

Ürün kalitesi ve dayanıklılığı, teknolojisi, fiyatı, satış sonrası hizmetleri ile müşteri memnuniyetini sağlayarak Türkiye ve dünya pazarında tercih edilen marka olmaktadır.

Misyonumuz

Ürünlerimiz, çözümlerimiz, satış sonrası hizmetlerimizle sağladığımız güvenilirlik ve yüksek iş ahlakımız ile müşterilerimizin ilk tercihi olarak, çalışanlarımız, ülkemiz ve müşterilerimiz için değer oluşturan bir şirket olmaktadır.

Vizyonumuz

En iyilerin çalışmak istediği ilham veren bir marka ve şirket olarak, müşterilerimize büyük fayda sağlayan ürün, sistem, hizmet ve çözümlerin üretilmesini sağlamaktır.

Pazar lideri olmanın getirdiği sorumluluk, bizlere daha iyiyi, daha güçlüyü ve daha yenilikçi olmayı yüklemektedir.

KONHIDROLIKSAN FARUK USTA HIDROLİK PRES proceeding for branding in hydraulic press industry with its experience and expertise of many years since 1982, aims for high quality production and plans its investment for realization of this purpose. Our experience is our assurance in providing optimum benefit and reliability for our customers. Our company, creating difference by bringing integrated solutions aims not to be a follower of, but an pacesetter for innovations.

KONHIDROLIKSAN, aiming for corporate management with its expert staff is conducting professional manufacturing to repeat its domestic success in foreign markets.

As KONHIDROLIKSAN, our main objective is to manufacture high quality hydraulic press upto the needs and expectations of our customers and enable sound and sustainable growth by providing after-sale services.

We want to be a brand of preference by ensuring customer satisfaction by product quality and endurance, technology, price and after-sale services.

Our Mission

Our mission is to be a company creating value for our employee, country and customers by being a first choice for our customers by our products, solutions, reliability ensured by after-sale services and high code of conduct.

Our Vision

Our vision is to ensure providing products, system, service and solutions to our customers by being an inspiring brand and company where the best would like to work in.

The responsibility coming from by being a market leader bears us the responsibility to be better, stronger and more innovator.



İstenilen Her Ölçüde Pres İmalatı Yapılır
It is Produced Press in Every Size



Atölye Tipi Presler

Hydraulic Workshop Presses

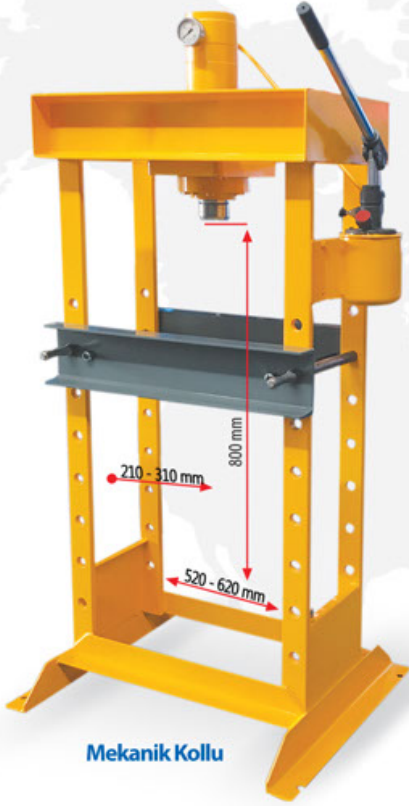

Mekanik Kollu

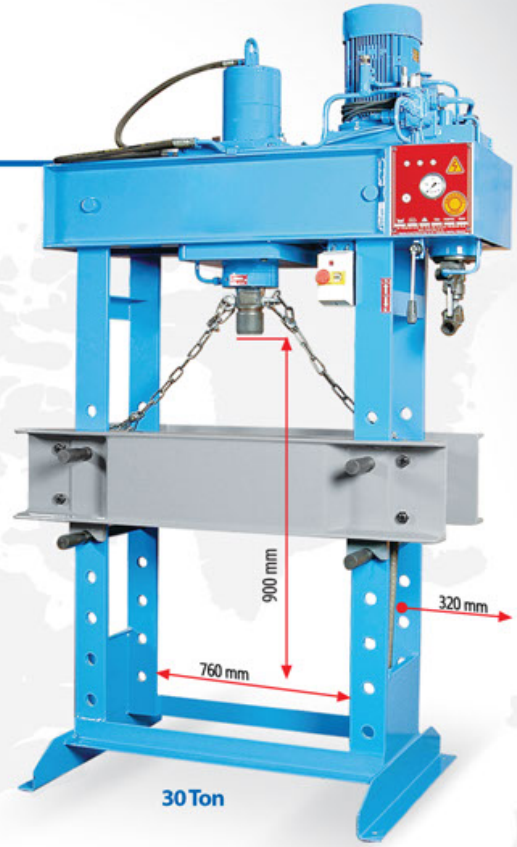

30 Ton

Motorlu, Kollu ve Gezer Silindirli

Motorized and Hand Operated with Movable Cylinder

Teknik Özellikler

Technical Specifications

	20 TON	30 TON	30 TON
Kapasite / Capacity	Kollu / Manuel	Kollu / Manuel	Motorlu / Motorized
A (mm)	1800	1800	2250
B (mm)	650	650	880
C (mm)	800	900	1150
D (mm)	520	620	760
E (mm)	210	210	310
H (mm)	710	810	900
Stroke (mm)	150	150	400
Motor (kw)	-	-	3
Pompa / Pump (lt)	-	-	6.5
Ağırlık / Weight (kg)	180	215	640

Standart Ekipmanlar

Standart Equipments

- Krom Kaplı Silindir / Chrome Plated Cylinder
- Kaynatılmış Çelik Gövde / Steel Welded Frame
- Basınç Göstergesi / Oil Pressure Gauge
- Basınç Ayarı / Pressure Adjustable
- Kullanma Kılavuzu / User Manual
- 2 Yıl Garanti / 2 Year Warranty

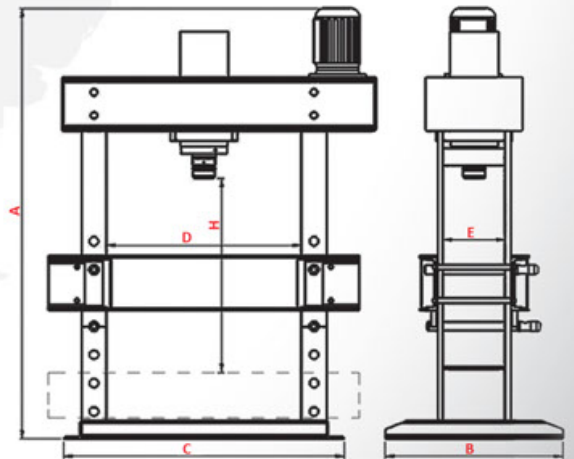

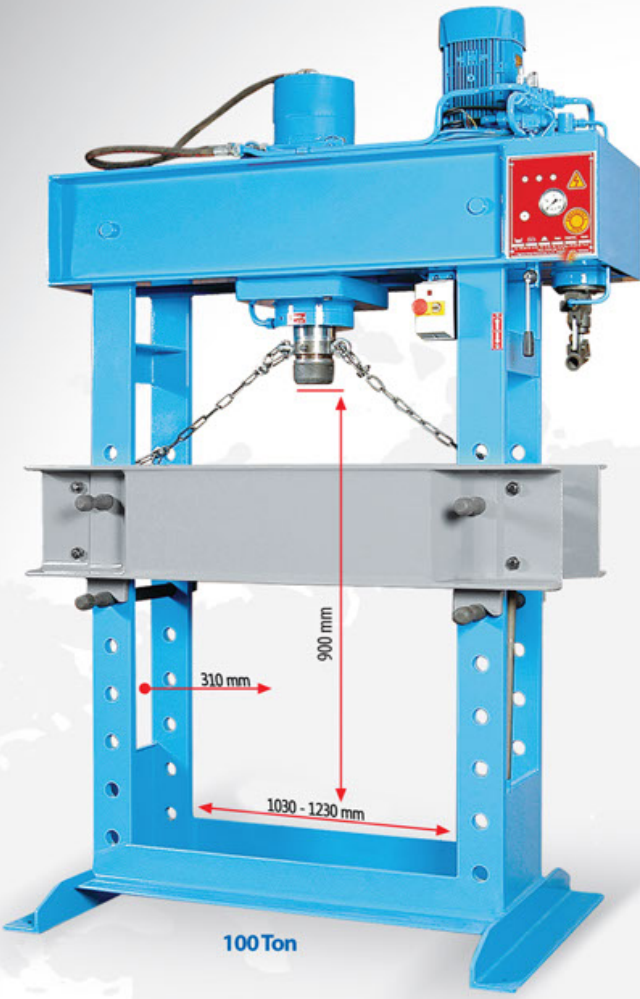

100 Ton

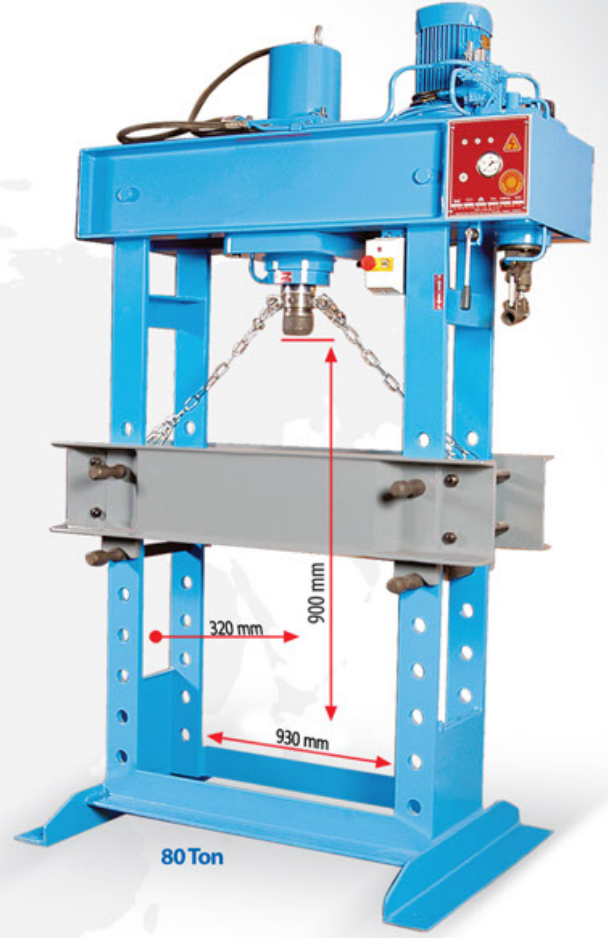

80 Ton

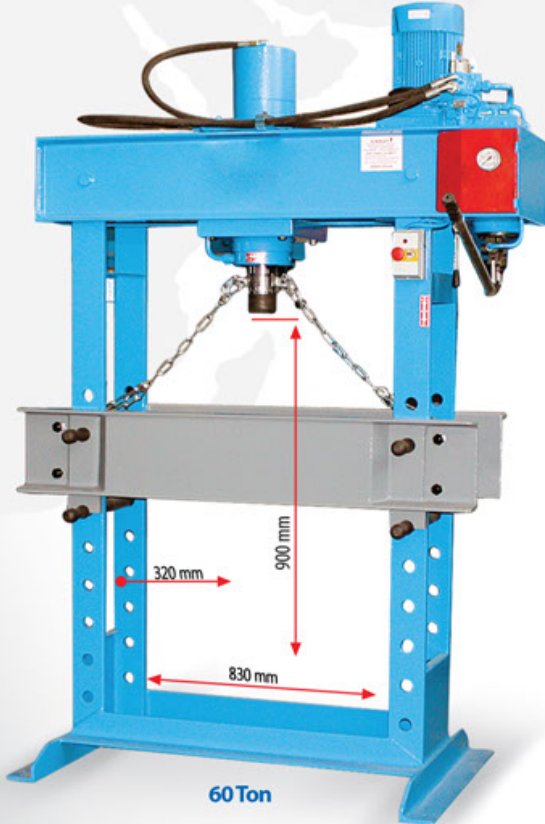

60 Ton

Motorlu, Kollu ve Gezer Silindirli Motorized and Hand Operated with Movable Cylinder

Teknik Özellikler Technical Specifications

	60 TON	80 TON	100 TON
Kapasite / Capacity	Motorlu / Motorized	Motorlu / Motorized	Motorlu / Motorized
A (mm)	2250	2350	2400
B (mm)	860	860	880
C (mm)	1210	1360	1490
D (mm)	830	930	1030
E (mm)	310	310	310
H (mm)	900	900	900
Stroke (mm)	400	400	400
Motor (kw)	3	3	4
Pompa / Pump (lt)	6.5	6.5	11
Ağırlık / Weight (kg)	685	735	950

İstenilen Her Ölçüde Pres İmalatı Yapılır
It is Produced Press in Every Size



Atölye Tipi Presler

Hydraulic Workshop Presses

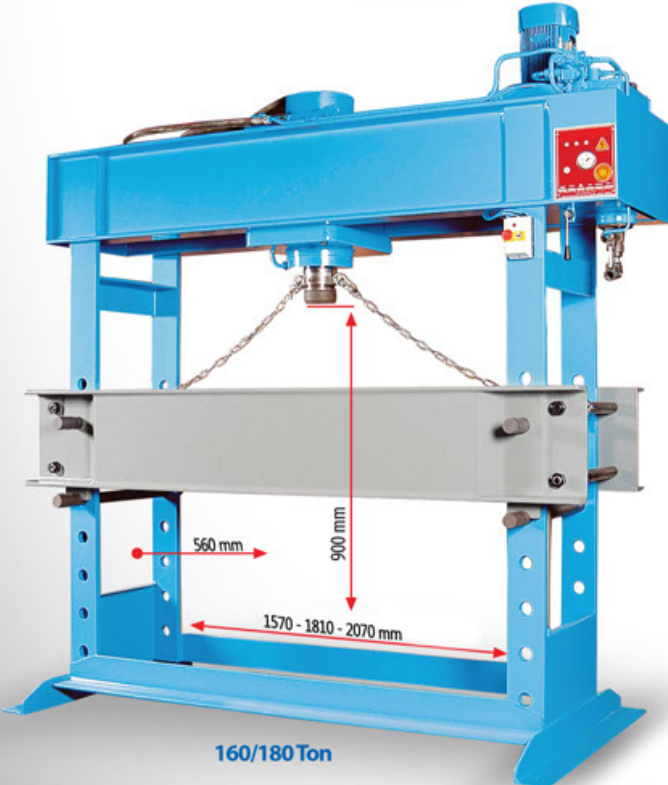
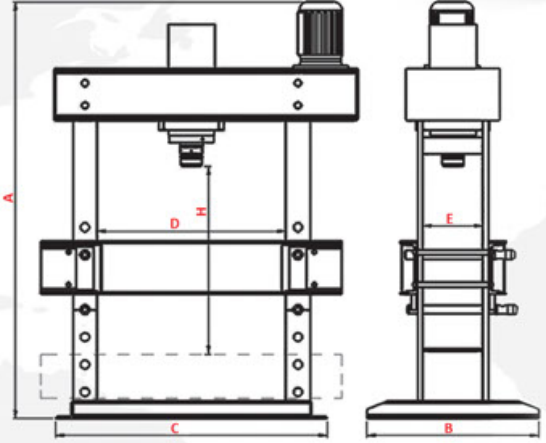
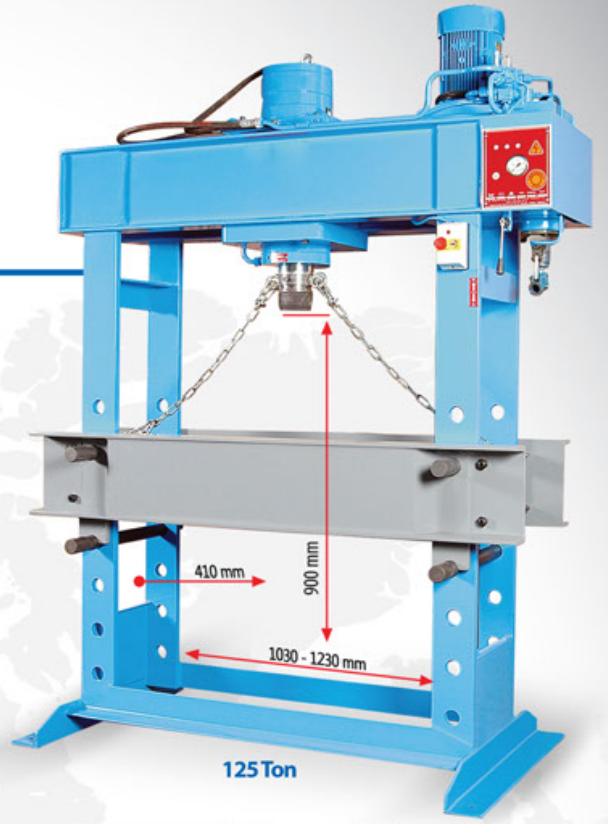
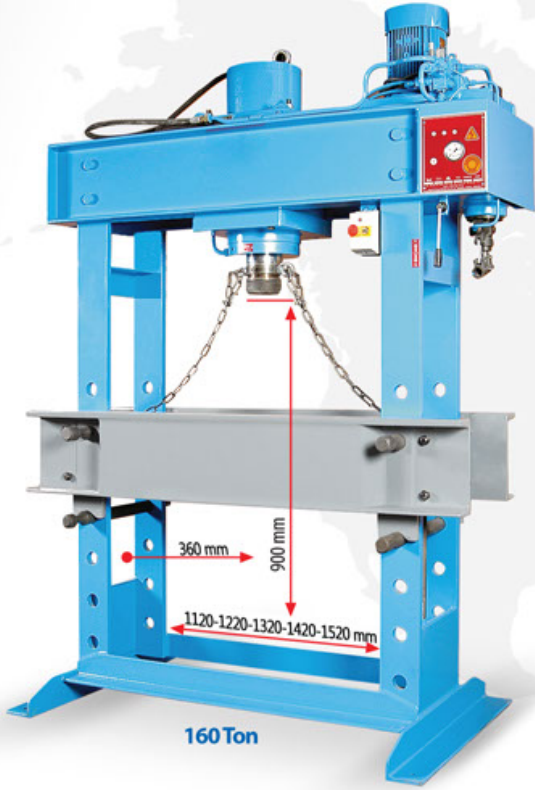

Motorlu, Kollu ve Gezer Silindirli
Motorized and Hand Operated with Movable Cylinder

Teknik Özellikler

Technical Specifications

	125 TON	160 TON	180 TON
Kapasite/Capacity	Motolu/Motorized	Motolu/Motorized	Motorlu/Motorized
A (mm)	2400	2550	2750
B (mm)	960	960	1200
C (mm)	1680	1590	2170
D (mm)	1220	1120	1570
E (mm)	410	360	560
H (mm)	900	900	900
Stroke (mm)	400	400	400
Motor (kw)	4 kw	5.5 kw	7.5 kw
Pompa / Pump (lt)	11	15	22
Ağırlık / Weight (kg)	1260	1320	1640

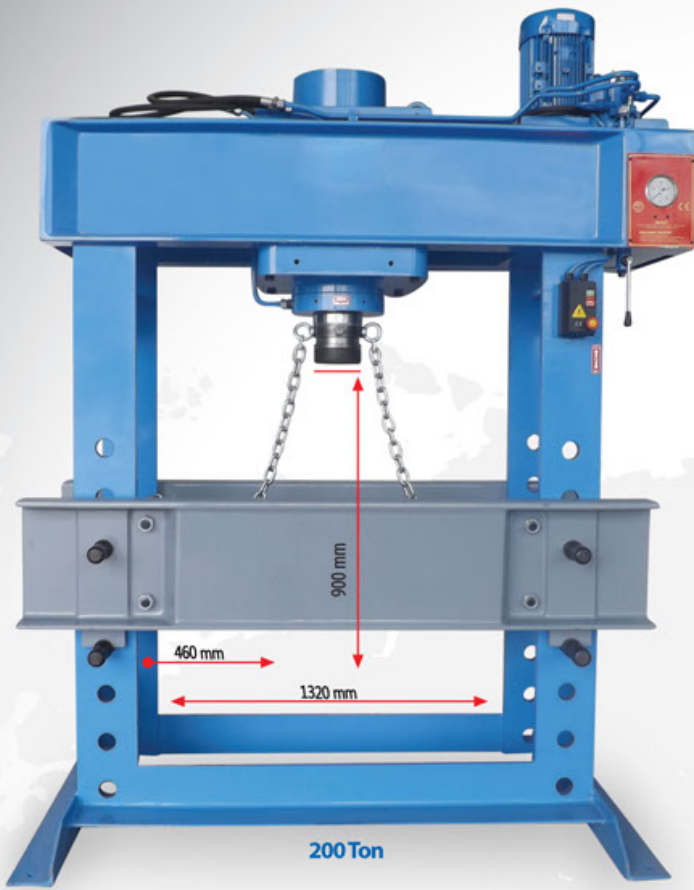

200 Ton

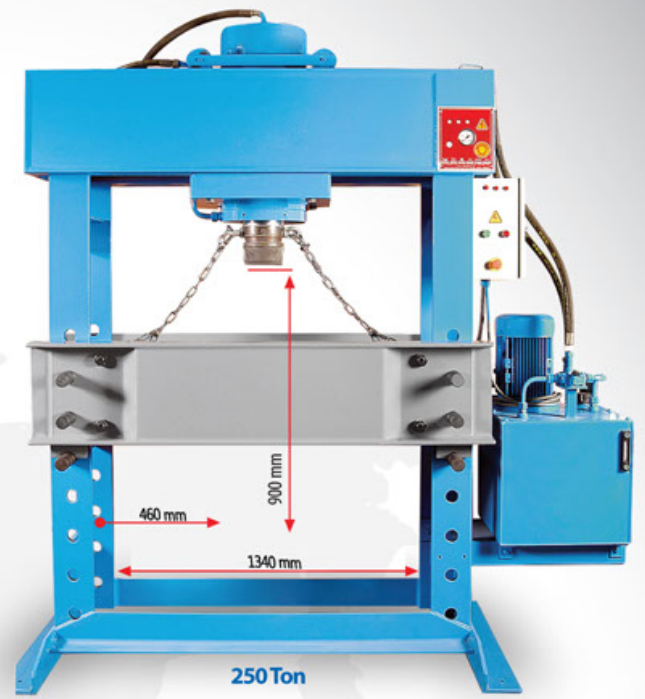

250 Ton

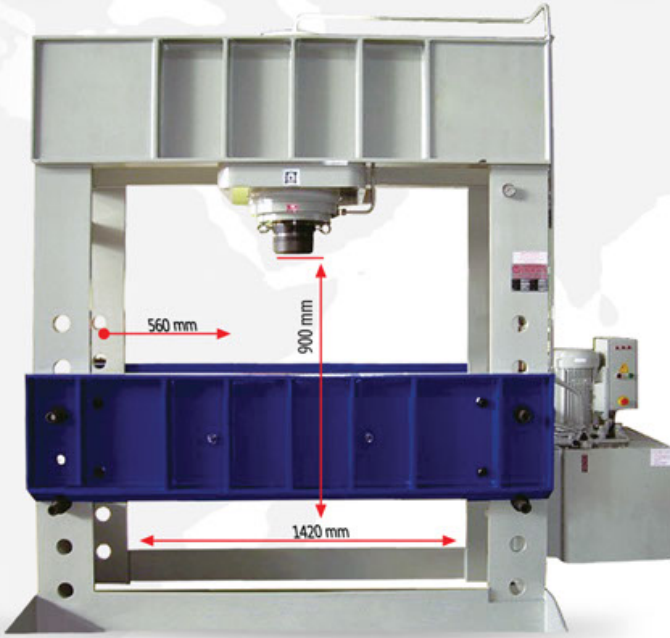

300 Ton Motorlu Sabit Silindir

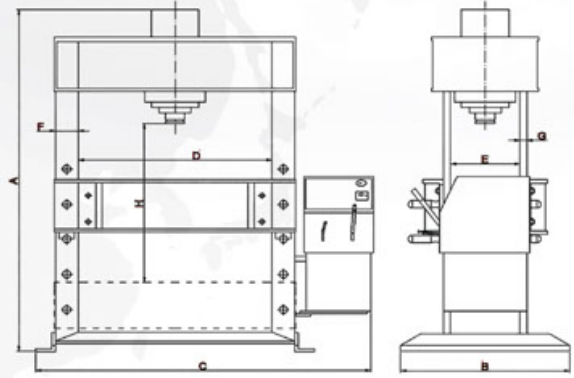

Motorlu, Kollu ve Gezer Silindirli

Motorized and Hand Operated with Movable Cylinder

Teknik Özellikler

Technical Specifications

Kapasite / Capacity	TON	200	250	300
A Yükselik / Height	mm	2800	2550	3000
B Ayak Boyu / Base Length	mm	1200	1220	1320
C Pres Geniřliđi / Press Wideness	mm	2020	2040	2470
D İki Sütun Arası / Between Two Column	mm	1320	1340	1420
E İki Sütun Arası En / Between Two Column Width	mm	460	460	560
H İş Alma Kapasitesi / Working Capacity	mm	900	900	900
Piston Stroku / Piston Stroke	mm	400	400	400
Hidrolik Pompa / Hydraulic Pump	lt	22	35	50
Motor Gücü / Motor Power	kw	7.5	15	20
Toplam Ađırlıđı / Total Weight	kg	2350	2650	4100

Standart Ekipmanlar

Standart Ekipmanlar

- Krom Kaplı Silindir / Chrome Plated Cylinder
- Kaynatılmış Çelik Gövde / Steel Welded Frame
- Basınç Göstergesi / Oil Pressure Gauge
- Basınç Ayarı / Pressure Adjustable
- Kullanma Kılavuzu / User Manual
- 2 Yıl Garanti / 2 Year Warranty

İstenilen Her Ölçüde Pres İmalatı Yapılır
It is Produced Press in Every Size



Atölye Tipi Presler

Hydraulic Workshop Presses

20 - 300 Tona Kadar Seri Üretim

300 - 600 Tona Kadar Özel Ölçü ve Özelliklerde Üretim

20 - 300 Tons Serial Production

300 - 600 Tons Production in Special Sizes and Specifications

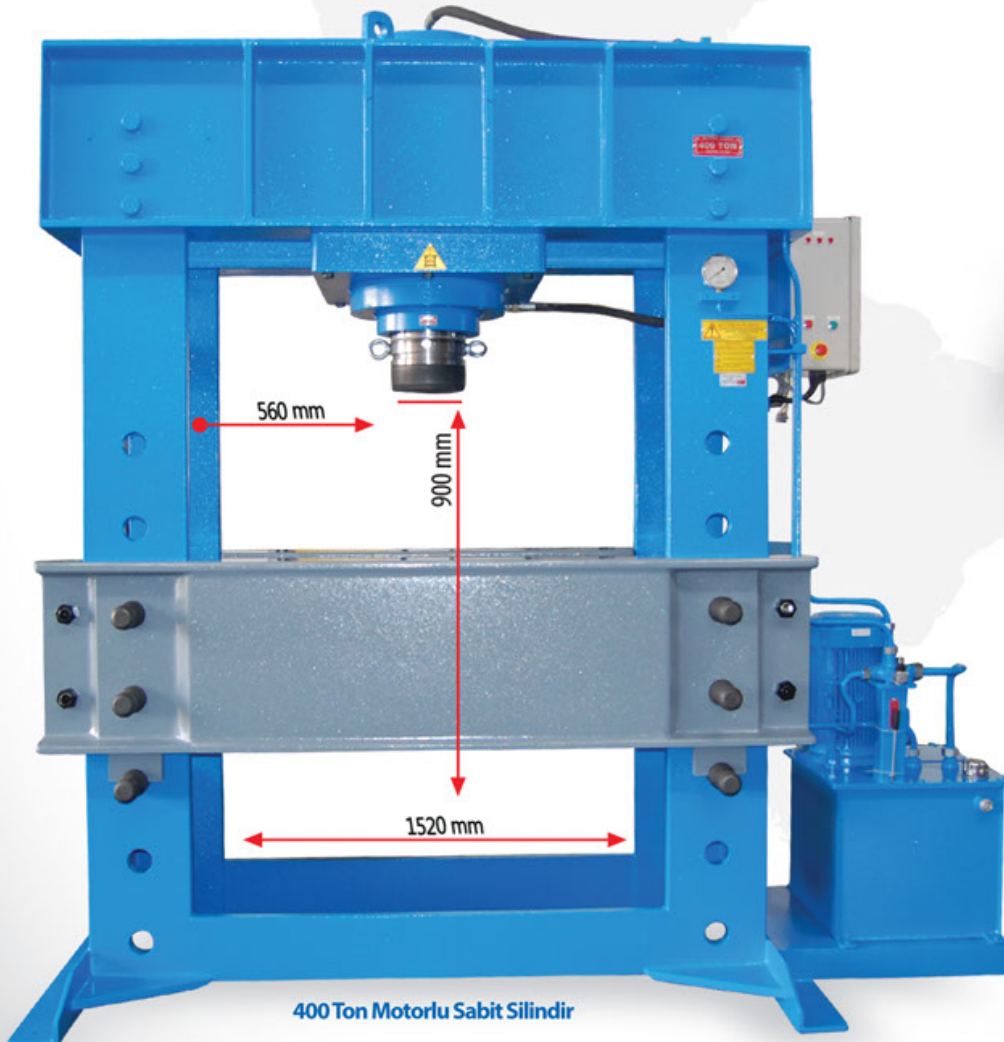

400 Ton Motorlu Sabit Silindir

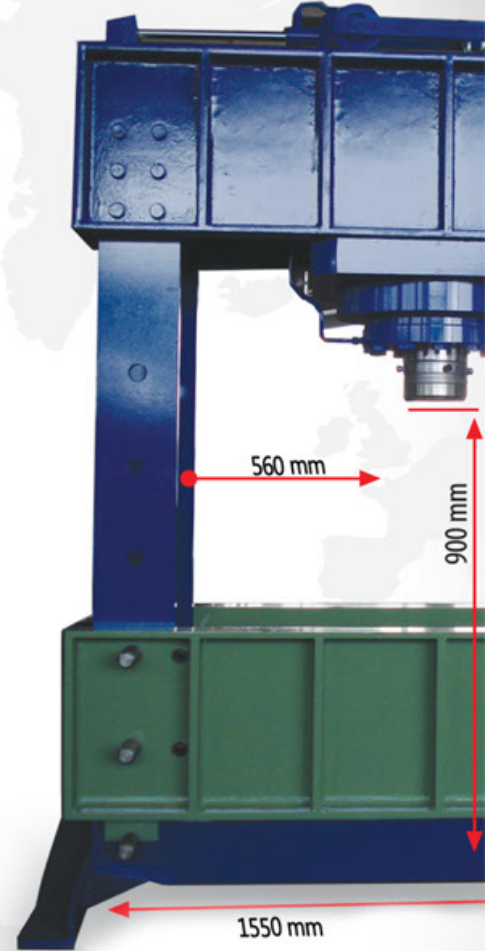

500 Ton Motorlu Sabit Silindir

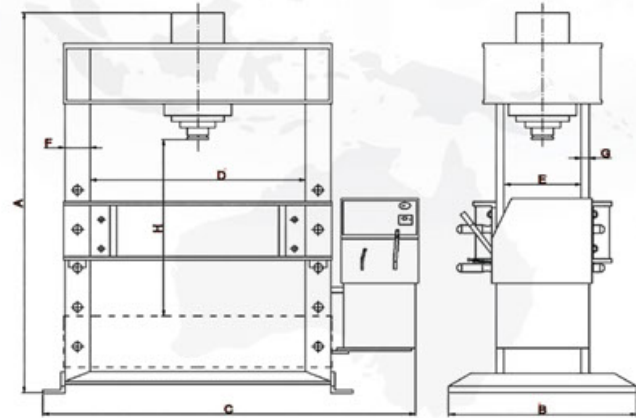

Standart Ekipmanlar Standart Equipments

Krom Kaplı Silindir / Chrome Plated Cylinder
Kaynatılmış Çelik Gövde / Steel Welded Frame
Basınç Göstergesi / Oil Pressure Gauge
Basınç Ayarı / Pressure Adjustable
Kullanma Kılavuzu / User Manual
2 Yıl Garanti / 2 Year Warranty

İstenilen Her Ölçüde Pres İmalatı Yapılır
It is Produced Press in Every Size



Hidrolik Büküm Presleri

Hydraulic Press Brake

Standart Ekipmanlar

Standart Equipments

- Krom Kaplı Silindir / Chrome Plated Cylinder
- Kaynatılmış Çelik Gövde / Steel Welded Frame
- Basınç Göstergesi / Oil Pressure Gauge
- Basınç Ayarı / Pressure Adjustable
- Bükme Kalıbı / Bending Tools
- Manuel Arka Dayama / Manual Back Gauge
- Kullanma Kılavuzu / User Manual
- 1 Yıl Garanti / 1 Year Warranty

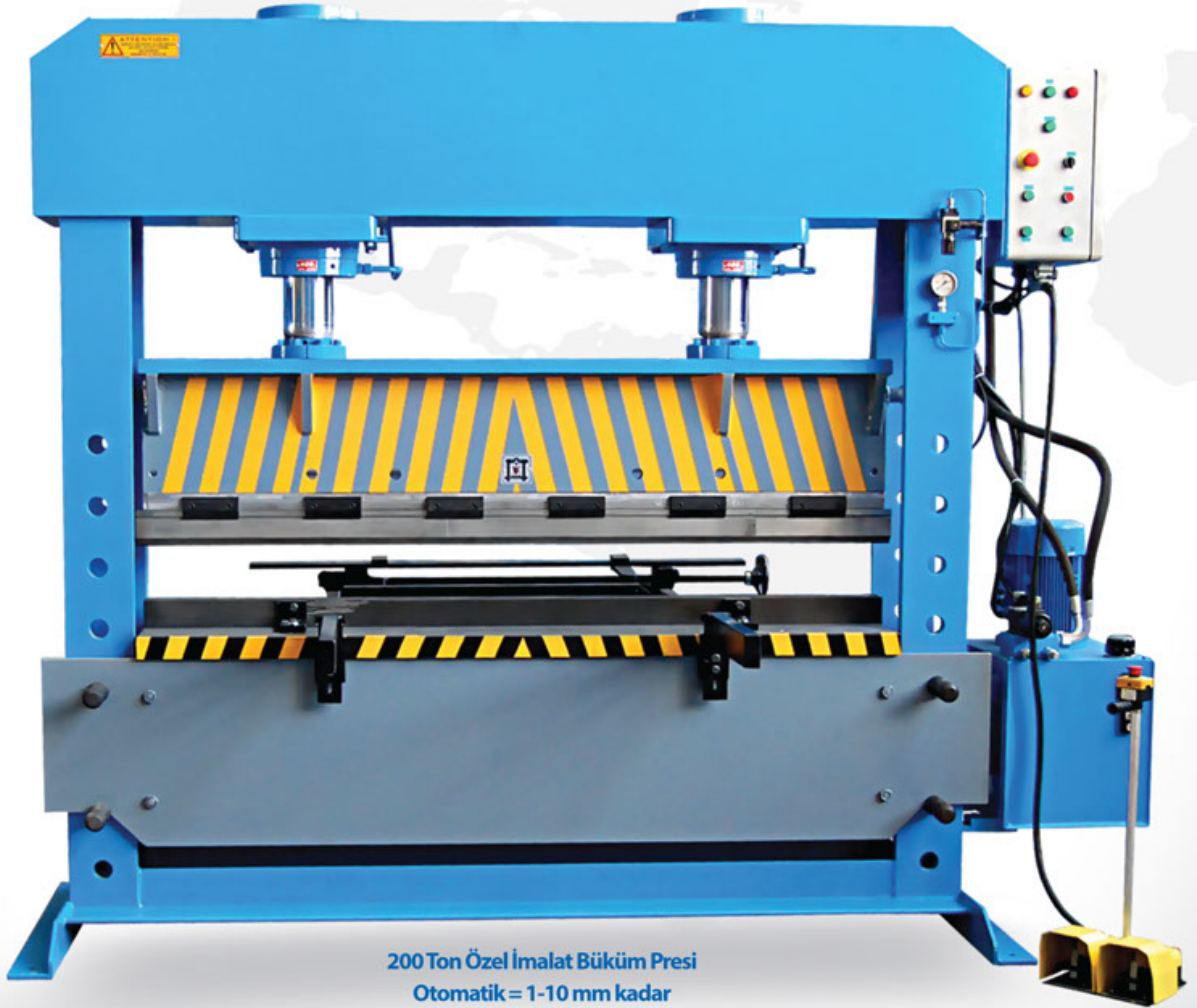

200 Ton Özel İmalat Büküm Presi
Otomatik = 1-10 mm kadar



Hidrolik Hortum Sıkma Presleri

Hydraulic Hose Crimping Presses



Teknik Özellikler Technical Specifications

3" Hortum Sıkma Presi

Sıkma Çapı / Crimping Inside Diameter	: Ø 14.5 mm to 101 mm
Max. Açıklık / Max Opening	: 115 mm
Sıkma Hassasiyeti / Crimping Precision	: 0.02 mm
Nominal Basınç / Rated Pressure	: 30 Mpa
Güç / Power	: 4 kw
Voltaaj / Voltage	: 380V 50 Hz
Nominal Debi / Rated Flow	: 11 L/min
Kalıp / Die	: 12 dies
Ölçüler / Dimensions	: 1200 x 600 x 1200 LxWxH mm
Ağırlık / Weight	: 700 kg

Kalıp Çap mm Ø Mold Dia mm Ø	Kalıp Uzunluk mm Ø Mold Dia mm Ø
14,5	80
17,5	80
19	80
22,5	80
25	80
29	80
34,5	80
41,5	80
54	80
61	80
70	80
86	80

İstenilen Her Ölçüde Pres İmalatı Yapılır
It is Produced Press in Every Size



Hidrolik C Tipi Presler

Hydraulic C Type Presses



60 Ton Otomatik C Tipi Özel Amaçlı Işık Bariyerli Pres

250 Tona Kadar Özel Ölçü ve Özelliklerde Üretim
250 Tons Production in Special Sizes and Specifications



100 Ton PLC Kontrol C Tipi Özel İmalat



30 - 60 Ton Otomatik
Mutfak Büküm Presi

Standart Ekipmanlar Standart Equipments

- Krom Kaplı Silindir / Chrome Plated Cylinder
- Kaynatılmış Çelik Gövde / Steel Welded Frame
- Otomatik Kontrol Ünitesi / Automatic Control Unit
- Koruma Kapağı ve Işık Bariyeri / Safety Cover and Light Barrier
- Çift El Buton ile Kontrol / Two Hand Button Control
- Basınç Göstergesi / Oil Pressure Gauge
- Basınç Ayarı / Pressure Adjustable
- T Kanallı Tabla / T - Slotted Table
- Kullanma Kılavuzu / User Manual
- 1 Yıl Garanti / 1 Year Warranty

İstenilen Her Ölçüde Pres İmalatı Yapılır
It is Produced Press in Every Size



Hidrolik C Tipi Sivama Presler

Hydraulic C Type Deep Drawing Presses



250 Ton C Tipi Otomatik Sivama Presi

250 Tona Kadar Özel Ölçü ve Özelliklerde Üretim

250 Tons Production in Special Sizes and Specifications



**120 Ton Otomatik C Tipi
Ön Dolumlu, Hızlı Yavaş Konumlu,
PLC Kontrol Işık Bariyerli Ütuleme Presi**

**160 Ton C Tipi
Otomatik Aittan Çıkarıcı Pres**



Standart Ekipmanlar *Standart Equipments*

- Krom Kaplı Silindir / Chrome Plated Cylinder
- Kaynatılmış Çelik Gövde / Steel Welded Frame
- Basınç Göstergesi / Oil Pressure Gauge
- Basınç Ayarı / Pressure Adjustable
- Bükme Kalıbı / Bending Tools
- Manuel Arka Dayama / Manual Back Gauge
- Kullanma Kılavuzu / User Manual
- 1 Yıl Garanti / 1 Year Warranty

İstenilen Her Ölçüde Pres İmalatı Yapılır
It is Produced Press in Every Size



Hidrolik H Tipi Tek Tesirli Presler

Hydraulic H Type Single Action Presses



100 - 3000 Tona Kadar Özel Ölçü ve Özelliklerde Üretim
100 - 3000 Tons Production in Special Sizes and Specifications

Üretimlerimizde Farklı Tonaj ve Özelliklerde H Tipi Otomatik PLC Presler

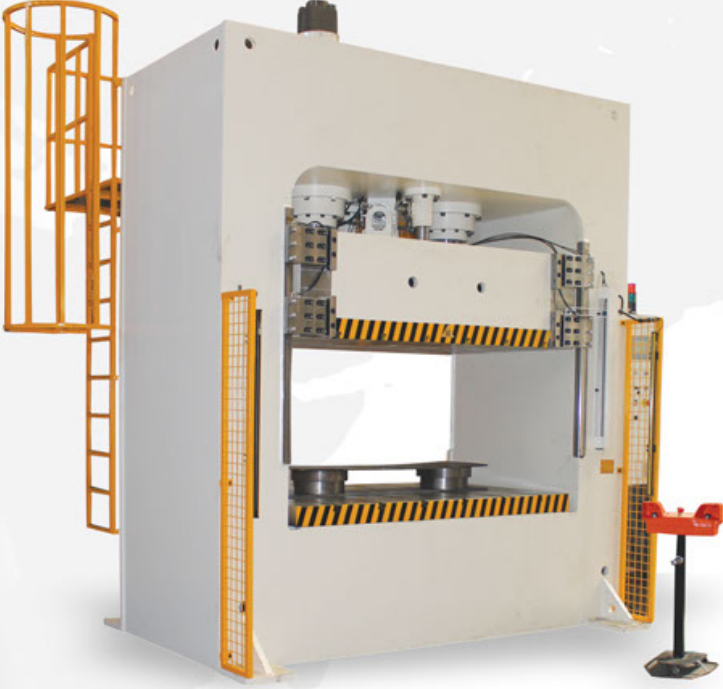

Standart Ekipmanlar

Standart Equipments

- Krom Kaplı Silindir / Chrome Plated Cylinder
- Kaynatılmış Çelik Gövde / Steel Welded Frame
- Otomatik Kontrol Ünitesi / Automatic Control Unit
- Koruma Kapağı ve Işık Bariyeri / Safety Cover and Light Barrier
- Çift El Buton ile Kontrol / Two Hand Button Control
- Basınç Göstergesi / Oil Pressure Gauge
- Yağlama / Lubrication
- Basınç Ayarı / Pressure Adjustable
- T Kanallı Tabla / T - Slotted Table
- Kullanma Kılavuzu / User Manual
- 1 Yıl Garanti / 1 Year Warranty

İstenilen Her Ölçüde Pres İmalatı Yapılır
It is Produced Press in Every Size



Hidrolik H Tipi Sivama Presler

Hydraulic H Type Deep Drawing Presses



1500 Ton Otomatik PLC Ütülleme Kalıp Alıştırma Presi

300 - 3000 Tona Kadar Özel Ölçü ve Özelliklerde Üretim
300 - 3000 Tons Production in Special Sizes and Specifications



600 Ton PLC Kontrol Otomatik Sıvama Presi
100x1400x1000 mm

Standart Ekipmanlar Standart Equipments

- Krom Kaplı Silindir / Chrome Plated Cylinder
- Kaynatılmış Çelik Gövde / Steel Welded Frame
- Otomatik Kontrol Ünitesi / Automatic Control Unit
- Koruma Kapağı ve Işık Bariyeri / Safety Cover and Light Barrier
- Çift El Buton ile Kontrol / Two Hand Button Control
- Basınç Göstergesi / Oil Pressure Gauge
- Basınç Ayarı / Pressure Adjustable
- T Kanallı Tabla / T-Slotted Table
- Kullanma Kılavuzu / User Manual
- 1 Yıl Garanti / 1 Year Warranty

İstenilen Her Ölçüde Pres İmalatı Yapılır
It is Produced Press in Every Size



Hidrolik Kolonlu Tek ve Çift Tesirli Presler

Hydraulic Column Frame Single / Double Action Presses

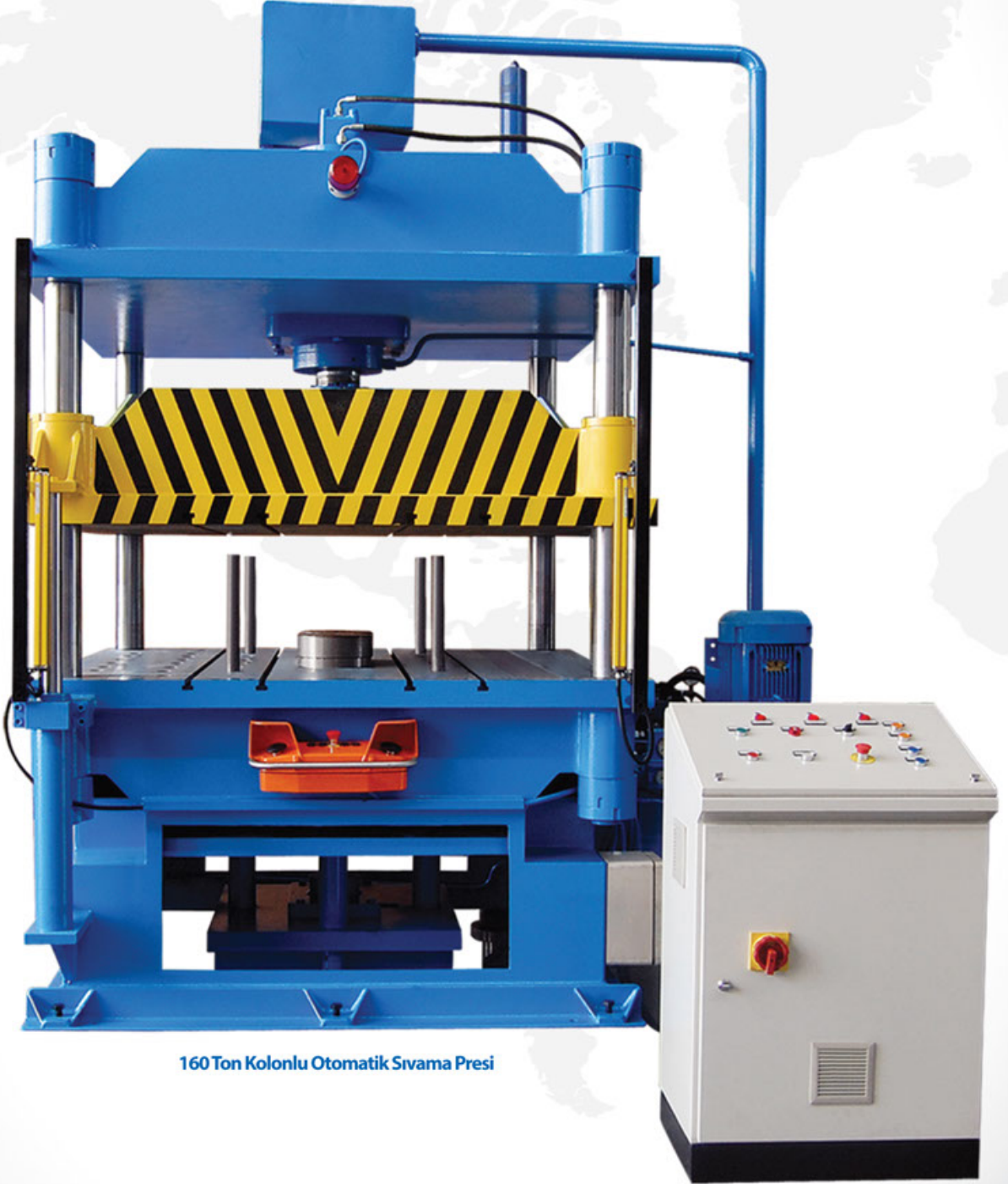

160 Ton Kolonlu Otomatik Sıvama Presi

1000 Tona Kadar Özel Ölçü ve Özelliklerde Üretim

1000 Tons Production in Special Sizes and Specifications



Hidrolik Sac Desen Presleri

Hydraulic Sheet Forming Presses



200 Ton Otomatik



600 Ton Otomatik Pres
4 Silindirli Özel Pres

Standart Ekipmanlar

Standart Equipments

- Krom Kaplı Silindir / Chrome Plated Cylinder
- Kaynatılmış Çelik Gövde / Steel Welded Frame
- Otomatik Kontrol Ünitesi / Automatic Control Unit
- Koruma Kapağı ve Işık Bariyeri / Safety Cover and Light Barrier
- Çift El Buton ile Kontrol / Two Hand Button Control
- Basınç Göstergesi / Oil Pressure Gauge
- Yağlama / Lubrication
- Basınç Ayarı / Pressure Adjustable
- T Kanallı Tabla / T - Slotted Table
- Kullanma Kılavuzu / User Manual
- 1 Yıl Garanti / 1 Year Warranty

İstenilen Her Ölçüde Pres İmalatı Yapılır
It is Produced Press in Every Size



Hidrolik Sıcak Kauçuk Presleri

Hydraulic Hot Rubber Presses



Standart Ekipmanlar

Standart Equipments

- Krom Kaplı Silindir / Chrome Plated Cylinder
- Kaynatılmış Çelik Gövde / Steel Welded Frame
- Otomatik Kontrol Ünitesi / Automatic Control Unit
- Koruma Kapağı ve Işık Bariyeri / Safety Cover and Light Barrier
- Çift El Buton ile Kontrol / Two Hand Button Control
- Basınç Göstergesi / Oil Pressure Gauge
- Yağlama / Lubrication
- Basınç Ayarı / Pressure Adjustable
- T Kanallı Tabla / T - Slotted Table
- Kullanma Kılavuzu / User Manual
- 1 Yıl Garanti / 1 Year Warranty
- Gaz Atma Sistemi / Bumping System

400 Ton Otomatik PLC Kontrol
1200x1200x600 mm

1000 Tona Kadar Özel Ölçü ve Özelliklerde Üretim

1000 Tons Production in Special Sizes and Specifications



Hidrolik Platine Doğrultma Presleri

Hydraulic Platinum Straightening Presses



300 Ton Otomatik Gezer Silindir
Tabla Sabit Kule Gezer
Platine Doğrultma Presi

Standart Ekipmanlar *Standart Equipments*

- Krom Kaplı Silindir / Chrome Plated Cylinder
- Kaynatılmış Çelik Gövde / Steel Welded Frame
- Kumanda ile Kontrol / Controlled by Pendant
- X-Y-Z Eksenler Motor Hareketli / X-Y-Z Axis Movement by Motorized
- İstenilen Pozisyonda Durabilir / Stroke Kontrol in Any Position
- Basınç Göstergesi / Oil Pressure Gauge
- Basınç Ayarı / Pressure Adjustable
- Tabla / Table (Tabla Dizaynı İsteğe Göre - Table Design According to Customer Needs)
- Kullanma Kılavuzu / User Manual
- 1 Yıl Garanti / 1 Year Warranty

İstenilen Her Ölçüde Pres İmalatı Yapılır
It is Produced Press in Every Size



Hidrolik Pres Sistemleri

Hydraulic Presses Systems



FARUK USTA HİDROLİK PRES MAK. SAN. ve TİC. LTD. ŞTİ.

- 📍 Fevzi Çakmak Mah. 10756 Sk. No:1F Karatay - KONYA / TURKEY
- ☎️ +90 332 346 00 12
- 📞 +90 332 346 00 23
- ✉️ info@konhidroliksankon.com
- 🌐 www.konhidroliksankon.com

Turkey
Discover
the potential



OLİKSAN